

<b>MV One Line.....</b>	<b>15-2</b>
<b>Motor Control – Medium Voltage (Limitamp®)</b>	
Introduction, Features, Types, Options, References.....	15-3
Specifications, Ratings, Equipment	
Reference Publications.....	15-4
Product Scope.....	15-5
Renewal Parts.....	15-6
<b>Switchgear Type – PowerVac</b>	
Introduction, Publications.....	15-8
POWER/VAC Vacuum Metalclad Switchgear,	
and Breakers.....	15-9
Characteristics, Symmetrical Rating Basis.....	15-10
Vacuum Circuit Breakers and Frames.....	15-11
<b>Switchgear Type – PV System 27 and PV System 38.....</b>	<b>15-12</b>
Introduction.....	15-12
Weights and Dimensions, Typical Sections.....	15-13
Circuit Breaker Characteristics.....	15-14
<b>Switchgear Type – Arc Resistant.....</b>	<b>15-15</b>
Introduction.....	15-15
Type 1 and Type 2 Configuration.....	15-16
Standards, Ratings, and Dimensions, Typical Sections.....	15-17
<b>Metal Enclosed Load Interrupter Switches</b>	
Introduction.....	15-19
Typical User Configurations.....	15-20
Technical Dimensions.....	15-20
Features.....	15-22
<b>Current-Limiting Power Fuses.....</b>	<b>15-23</b>

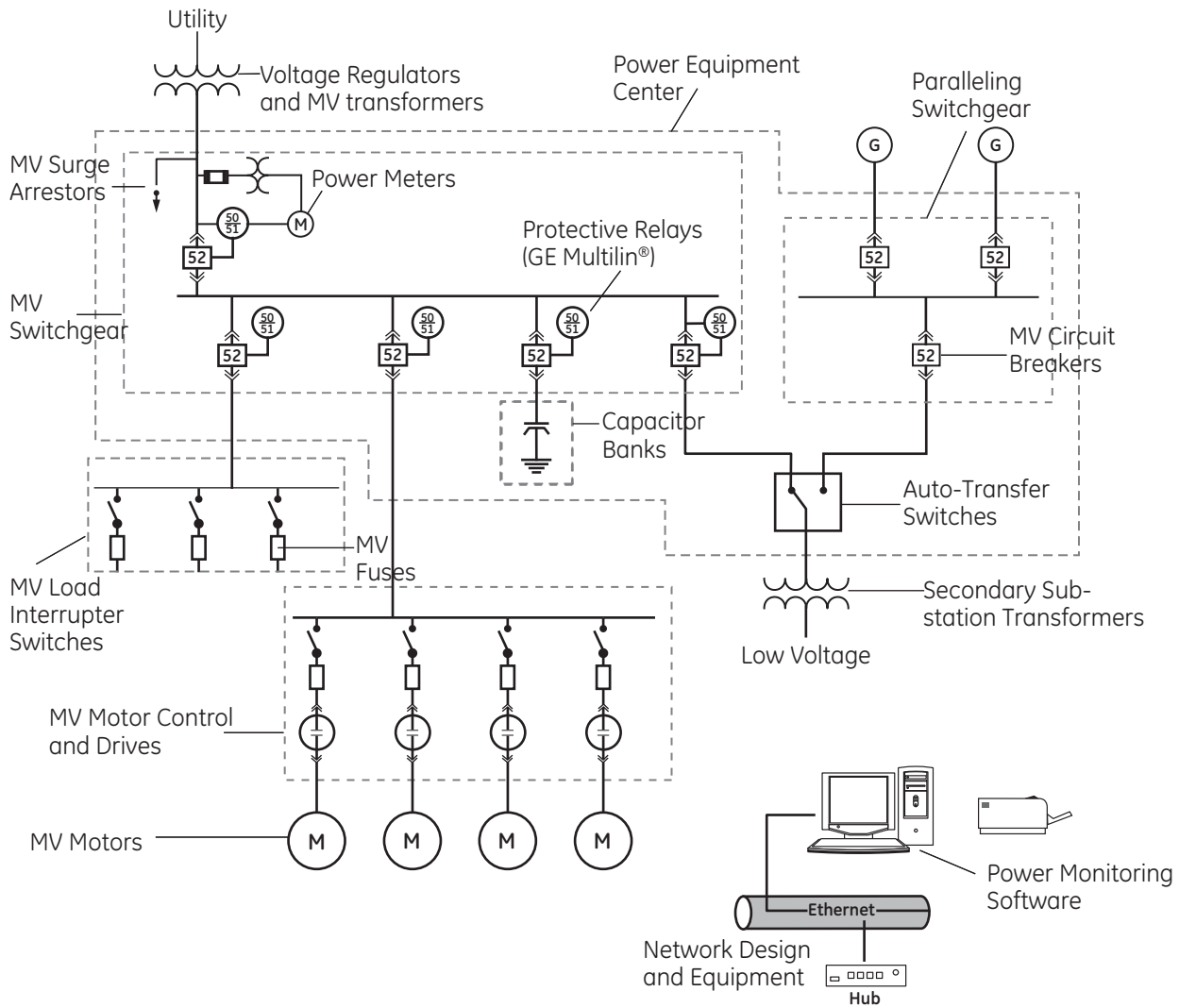



# Medium Voltage Equipment

## Motor Control – Limitamp®

### Limitamp Medium Voltage Motor Control

2400-7200 Volts

The GE Limitamp motor control center provides an economical means of centralizing motor starters and related control equipment. It permits motor control starters, feeders, isolator switches, distribution transformers, interlocking relays, programmable control, metering and other miscellaneous devices to be obtained in a single floor-mounted structural assembly fed from a common enclosed main bus.

Limitamp motor control centers are constructed of standardized heavy gauge vertical sections housing vertical and horizontal buses and compartmented starters. Sections are bolted together to form a single line-up assembly. The entire center may be powered by incoming line connection at a single point. When requested and possible, Limitamp motor control centers bear UL section and unit labels.

Limitamp Control is designed to meet NEMA ICS 3, Part 2 and UL 347 requirements. Various enclosure types and constructions are available and there is a broad selection of modifications for complete control and protection of motors used on modern power-utilization systems with high available short-circuit currents.

Limitamp AR is the Arc Resistant version of the Limitamp, providing a state of the art solution under arc flash conditions, increasing the safety and protection defined in the applicable IEEE C37.20.7-2007 – Type 2B standards.

The Limitamp AR is available for Full Voltage Non Reversing motor starters, maintaining the same basic characteristics as the CR194 Limitamp and the vacuum contactor.

**This program is limited and restricted. Please contact your distributor or GE for scope, pricing, and ordering.**

#### Product Features

- Visible blade disconnect switch
- Proven, high reliability vacuum contactors (2 million operations)
- Quick-make / quick-break disconnect switch
- Modular, flexible enclosure construction
- Extensive protective relays from GE Multilin®
- Epoxy insulated bus available
- Drawout and stationary contactors
- 1 high and 2 high arrangements
- UL / cUL available on most units
- Large isolated low voltage compartment
- No rear access required
- Matching line-up with all existing Limitamp installed equipment

AR version:

- Reinforced doors and panels to guarantee appropriate protection under arc flash conditions
- Internal construction to ensure the arc flash products and gases are directed to the upper section of the enclosure
- State of the art vent/flap mechanism to allow the gases to evacuate the enclosure and be contained in the Arc Duct or Plenum
- Arc Plenum on top of each arc resistant vertical section with provision to be extended as required



#### Starter Types

- FVNR Full voltage non-reversing (induction and synchronous)
- RVAT Reduced voltage autotransformer
- RVPR Reduced voltage primary reactor
- FVR Full voltage reversing
- 2S1W Two-speed, one winding
- 2S2W Two-speed, two winding
- MVSS Medium voltage solid state
- Feeders Transformer feeders

#### Construction Options

- Main bus: 1200A, 2000A, 3600A (AR version up to 2000A)
- System voltages: 2400V, 3300V, 3600V, 4160V, 4800V, 6600V, 7200V
- Contactor sizes: 400A, 800A (400A only available for AR version)
- Enclosure types: NEMA 1, 1A, 2, 3R, (Limitamp AR only for indoor) 12
- Bus bracing: 50 KA symmetrical

#### Limitamp Medium Voltage Motor Control

#### Product References:

Engineered Products Catalog	Section 11
Application and Selection Guide	GET-6840



# Medium Voltage Equipment Motor Control – Limitamp® Limitamp Medium Voltage Motor Control 2400-7200 Volts

### Key Product Specifications

#### Main AC Horizontal Bus Ratings

- 1200A, 2000A (1950A non-ventilated), or 3600A (2800 non-vented)
- 50 kA rms sym short circuit
- Tin or silver plating available
- Epoxy insulation available
- Matching line-up with all existing Limitamps (including Air Break)
- Auxiliary sections available for the Limitamp AR

#### Typical Current Ratings (amps) 2 HI only

- Vented: 360 top/400 bottom
- Non-vented: 320 top/320 bottom
- Arc Resistant: Non-vented 320 top/320 bottom

#### Interrupting Ratings

Class E1 mVA	25 at 2.5kV
	50 at 5.0kV
	75 at 7.2kV
Class E2 mVA	
2400 volts	200
3600 volts	300
4160 volts	350
4800 volts	400
7200 volts	600

#### Contactor Ratings—CR193B and CR193D (400A)

Short-time current (amps)	
30 seconds	2400
1 second	6000
Impulse withstand (kV)	60
Dielectric strength (kV) 1 minute	18.2
Switching frequency (ops/hour)	360
Mechanical life (ops)	2,000,000
Electrical life (ops)	1,000,000
Closing time (max. ms)	350
Opening time (max. ms)	
switched at coil	50
Pick-up voltage (% of rated)	85% max.
Drop out voltage (% of rated)	10%-65%
Control voltage (volts) requires	
rectification	110/115 AC
Control circuit burden (VA)	
Closing	175
Hold-in	30
Contact weight	75 lbs. (35 kg)
Standards applicable	UL 347
	NEMA ICS 3, Part 2
	cUL

#### CR194 AR 400A, Stationary or Draw-out, Outline Dimensions

Description	Height (in.)	Width (in.)	Depth (in.)
1-High, 36" wide, BTM Cable Entry	90	36	42
1-High, 40" wide, BTM Cable Entry	90	40	42
1-High, 36" wide, TOP Cable Entry	90	36	42
1-High, 40" wide, TOP Cable Entry	90	40	42
2-High, 36" wide, BTM Cable Entry	90	36	42
2-High, 40" wide, BTM Cable Entry	90	40	42
2-High, 36" wide, TOP Cable Entry	90	36	42
2-High, 40" wide, TOP Cable Entry	90	40	42

### Publication References for Limitamp Equipment

Publication	Description	Stocking Location
<b>CR194 Vacuum Design</b>		
DEA-328	Medium Voltage Soft Starters	Bloomington <sup>1</sup>
GEH-6263	2-high Maintenance Instructions	Bloomington <sup>1</sup>
GEH-5305	1-high Maintenance Instructions	Bloomington <sup>1</sup>
GET-6840	Selection & Application	Bloomington <sup>1</sup>
DET-064	Advertising Brochure	Bloomington <sup>1</sup>
GEH-5396	800 Amp 1-high Maintenance	Bloomington <sup>1</sup>
GEF-8016	Contactors Renewal Parts	Mebane
GEH-5306	Contactors Maintenance Instructions	Bloomington <sup>1</sup>
<b>Fuses/Curves</b>		
GES-5000	Power Fuse Curves	Bloomington <sup>1</sup>
<b>General Purpose Controls</b>		
GEP-1260	Control Catalog—Covers Full Line of Products	Bloomington <sup>1</sup>
<b>Pilot Devices</b>		
GEA-10877	CR104P Push Buttons and Pilot Lights	Bloomington <sup>1</sup>
<b>Relays and Timers</b>		
GEH-4115	CR120B AC Relays	Bloomington <sup>1</sup>
GEH-4120	CR120B Latched Relays	Bloomington <sup>1</sup>
GEH-6248	CR4 Control and Timing Relay	Bloomington <sup>1</sup>
GEH-5475	C-2000 Mini-Contactors Control Relays	Bloomington <sup>1</sup>
1601-0057	Multilin 469	GE Multilin®
1601-0077	Multilin 369	GE Multilin®
1601-0025	Multilin 269	GE Multilin®
1601-0013	Multilin 269+	GE Multilin®
1601-0060	Multilin 239+	GE Multilin®
<b>Metering</b>		
GEH-6302	Power Leader® EPM, User's Guide	Bloomington <sup>1</sup>
GEH-5892	Power Leader®, User's Guide	Bloomington <sup>1</sup>

<sup>1</sup>Ordering address on BuyLog® page 22-1.

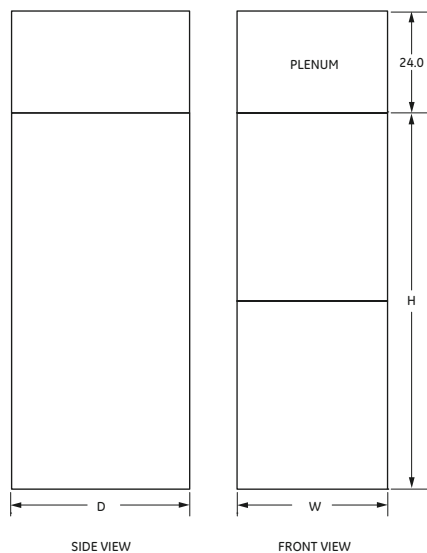

CR194 AR 400A Outline Dimensions



# Medium Voltage Equipment Motor Control – Limitamp®

## Limitamp Medium Voltage Motor Control 2400-7200 Volts

### Limitamp Product Scope

Product/ Application	Max. Fault Rating	Max. Current Rating (Amps)	Main Bus Rating <sup>1</sup>	Enclosure Size <sup>2</sup>	Power Fuse Types	Overload Relays <sup>3</sup>	Potential Transformers
One High CR194 400A <sup>5,13</sup> Vacuum Stationary Control (FVNR) (induction motor or transformer loads)	50 kA rms sym. <sup>11</sup> 4.80 kV (fused)	360A vented 320A non-vented	1200A 2000A 3600A <sup>12</sup> (2800A non-vented)	1-high <sup>14</sup> 26W x 90H x 30D (34W optional)	GE Type RB Bolted or Clip	CR324C Multilin 269+ <sup>10</sup>	N/A
Two High CR194 400A <sup>5,13</sup> Vacuum Stationary or Drawout (FVNR)	50 kA rms sym. <sup>11</sup> 7.2 kV (fused)	TOP: 360A vented 320A non-vented BOTTOM: 400A vented 320A non-vented	1200A <sup>8</sup> 2000A (1950A non-vented) 3600A <sup>12</sup> (2800A non-vented)	2-high <sup>14</sup> 36W x 90H x 30D (40W optional)	GE Type RB Bolted or Clip	CR324C Multilin 269+ <sup>10</sup>	N/A
One High CR194 800A <sup>5</sup> Vacuum Stationary or Drawout (FVNR) (induction motor or transformer loads)	50 kA rms sym. 4.80 kV (fused)	760A vented 640A non-vented	1200A & 2000A 3600A <sup>12</sup> (2800A non-vented)	1-high 480W x 90H x 30D	Ferraz Shawmut Type RB Bolted	CR324C Multilin 269+ <sup>10</sup>	N/A
CR7160 400A <sup>9</sup> Air-Break Drawout (FVNR) (induction motor or transformer loads)	50 kA rms sym. 4.80 kV (fused)	320A 1-high non-vented 360A 1-high vented 310A 2-high vented 250A 3-high vented 310A 3-high, with only 2 contactors	1000A & 2000A 3600A <sup>12</sup> (2800A non-vented)	1-high 34W x 90H x 30D (42W optional) 2-high & 3-high 44W x 90H x 30D	GE Type RA or RB	CR324C Multilin 269+	N/A
IC1074 1200A <sup>6</sup> Load Break Switch (stationary) (main, feeder, or tie)	38 kA rms sym. 4.76 kV (fused)	1200A vented w/o fuse 1000A non-vented w/o fuse 960A vented with fuse 840A non-vented with fuse	1000A & 2000A 3600A <sup>12</sup> (2800A non-vented)	38W x 90H x 30D	Ferraz Shawmut	N/A	ITI stationary drawout
Auxiliary Sections <sup>7</sup> (incoming line, metering auxiliary)	38 kA rms sym. 4.76 kV	Per devices installed	1000A & 2000A 3600A <sup>12</sup> (2800A non-vented)	90H x 30D any width available (22" minimum)	N/A	N/A	ITI stationary drawout

#### NOTES:

- 1 Copper only, silver or tin plating, insulation available.
- 2 NEMA 1 only, gasketing available. NEMA 2, 12, 3R available.
- 3 CR324 is ambient-compensated.
- 4 With primary and secondary fuses. Remote control power available.
- 5 Mechanical latch available. Capacitor trip device also available with latched contactor.
- 6 A switch may be used for isolation only.
- 7 Surge arresters available: GE #9L11XPB Polymer series.
- 8 Epoxy-coated.
- 9 Obsolete design-for replacement only.
- 10 Multilin 239, 269, 369, 469 available.
- 11 7.2 kV application available.
- 12 Adds 12 inches to depth.
- 13 Available in Arc Resistant Type 2B.
- 14 24 inch top for Plenum in AR version.



# Medium Voltage Equipment Motor Control – Limitamp®

## Frequently Requested Limitamp Renewal Parts

CR194 and CR7160

### Limitamp Renewal Parts

Limitamp Type Part	Description	CR194	CR7160	Product Number
Arc Chute Assembly	Load Break Switch		•	204B4051BTG1
Blade Assembly	Load Break Switch		•	204B4051BRG1
		N/A		9F60JD025
		N/A		9F60JD030
		N/A		9F60JD040
		N/A		9F60JD050
	9F60 Series	N/A		9F60JD065
		N/A		9F60JD080
		N/A		9F60JD100
		N/A		9F60JD125
		N/A		9F60JD150
		N/A		9F60JD200
		•	•	9F62HCB025
		•	•	9F62HCB030
		•	•	9F62HCB040
		•	•	9F62HCB050
	9F62 G.P. Series	•	•	9F62HCB065
E Rated Fuses	Equivalent Cont. Current Rating	•	•	9F62DCB080
		•	•	9F62DCB100
		•	•	9F62DCB125
		•	•	9F62DCB150
		•	•	9F62DCB175
		•	•	9F62DCB200
		•	•	9F62HCB025
		•	•	9F62HCB030
		•	•	9F62HCB040
	9F62 G.P. Series	•	•	9F62HCB050
	Equivalent XFMR Protection	•	•	9F62HCB065
		•	•	9F62DCB080
		•	•	9F62DCB125
		•	•	9F62DCB150
		•	•	9F62DCB175
	Air - Clip (5kV, 70A)	•	•	218A4291P2RB
	Air - Clip (5kV, 100A)	•	•	218A4291P3RB
	Air - Clip (5kV, 130A)	•	•	218A4291P4RB
	Air - Clip (5kV, 170A)	•	•	218A4291P6RB
	Air - Clip (5kV, 200A)	•	•	218A4291P9RB
	Air - Clip (5kV, 230A)	•	•	218A4291P12RB
	Air - Clip (5kV, 390A)	•	•	218A4291P18RB
	Air - Clip (5kV, 450A)	•	•	218A4291P24RB
	Air - Bolted (5kV, 70A)	•	•	218A4293P2RB
	Air - Bolted (5kV, 100A)	•	•	218A4293P3RB
	Air - Bolted (5kV, 130A)	•	•	218A4293P4RB
	Air - Bolted (5kV, 170A)	•	•	218A4293P6RB
	Air - Bolted (5kV, 200A)	•	•	218A4293P9RB
	Air - Bolted (5kV, 230A)	•	•	218A4293P12RB
	Air - Bolted (5kV, 390A)	•	•	218A4293P18RB
	Air - Bolted (5kV, 450A)	•	•	218A4293P24RB
	Vac. - Bolted (5kV, 70A)	•		55A212942P2RB
	Vac. - Bolted (5kV, 100A)	•		55A212942P3RB
	Vac. - Bolted (5kV, 130A)	•		55A212942P4RB
	Vac. - Bolted (5kV, 170A)	•		55A212942P6RB
	Vac. - Bolted (5kV, 200A)	•		55A212942P9RB
R Rated Fuses	Vac. - Bolted (5kV, 230A)	•		55A212942P12RB
	Vac. - Bolted (5kV, 390A)	•		55A212942P18RB
	Vac. - Bolted (5kV, 450A)	•		55A212942P24RB
	Vac. - Bolted - 800A (5kV, 425A)	•		55A213937P425B
	Vac. - Bolted - 800A (5kV, 550A)	•		55A213937P550B
	Vac. - Bolted - 800A (5kV, 630A)	•		55A213937P630B
	Vac. - Bolted - 800A (5kV, 800A)	•		55A213937P800B
	Air - Bolted (7.2kV, 70A)		•	218A4298P070
	Air - Bolted (7.2kV, 100A)		•	218A4298P100
	Air - Bolted (7.2kV, 180A)		•	218A4298P180
	Air - Bolted (7.2kV, 360A)		•	218A4298P360
	Vac. - Bolted (7.2kV, 70A)	•		55A212943P70
	Vac. - Bolted (7.2kV, 100A)	•		55A212943P100
	Vac. - Bolted (7.2kV, 180A)	•		55A212943P180
	Vac. - Bolted (7.2kV, 360A)	•		55A212943P360



# Medium Voltage Equipment Motor Control – Limitamp®

## Frequently Requested Limitamp Renewal Parts CR194 and CR7160

### Renewal Parts (continued)

Part	Description	Limitamp Type		Product Number
		CR194	CR7160	
R Rated Fuses <sup>1</sup>	Air or Vac Clip, 7.2kv, 70A	•	•	9F60LJE503
	Air or Vac Clip, 7.2kv, 130A	•	•	9F60LJE504
	Air or Vac Clip, 7.2kv, 170A	•	•	9F60LJE506
	Air or Vac Clip, 7.2kv, 200A	•	•	9F60LJE509
	Air or Vac Clip, 7.2kv, 230A	•	•	9F60LJE512
	Air or Vac Clip, 7.2kv, 390A	•	•	9F60MJE518
	Air or Vac Clip, 7.2kv, 450A	•	•	9F60MJE524
Control Power Transformer	0.75kVA 2400 to 230/115 Vac	•	•	573A350P86
	0.75kVA 4160 to 230/115 Vac	•	•	573A350P87
	2kVA 2400 to 230/115 Vac	•	•	573A350P44
	2kVA 4160 to 230/115 Vac	•	•	573A350P45
	3kVA 4160 to 230/115 Vac	•	•	573A350P53
Primary Fuses	3kVA 2400 to 230/115 Vac	•	•	573A350P54
	1 Amp (Use with .75kVA)	•	•	CSC#A480T1E-1
	3 Amp (Use with 2kVA)	•	•	CSC#A480T3E-1
Repl. Bottles	Refer to Factory	•	•	CSC#A480T4E-1
	Vacuum Contactors	•	•	

This is a partial listing of GE's medium voltage power fuse offering. GE offers current limiting fuses for a large variety of applications, including full range fuses, potential transformer fuses, motor starters, capacitor fuses, supports, disconnect switches, and a variety of fuse clips and live parts.

For more information, please contact your local GE distributor, or local GE Energy sales representative. Our catalog (GEP-9013B), as well as other application and selection information are also available at [www.geindustrial.com](http://www.geindustrial.com). If you need further assistance you may contact our customer service group at 1-800-821-4873 (US only).

<sup>1</sup>GO-P001 for all R-Rated Fuses on this page only.

### Limitamp Parts Publications List

Model	Description	Number
CR194	Instructions (One-High) 400A	GEH-5305
	Instructions (Two-High) 400A	GEH-6263
	Renewal Parts 400A	DEF-002
CR7160 Air Break	Instructions 800A	GEH-5396
	Instructions and Maintenance	GEH-3091
CR-193 Vac. Contactor	Renewal Parts	GEF-4630
	Maintenance	GEH-5306
	Renewal Parts	GEF-8016
Air Break Contactor (IC2814 and IC302)	Instructions and Maintenance	GEH-3102
	Renewal Parts 400A	GEF-4551
	Renewal Parts 700A	GEF-4576
CR7160 Drawout Vac. Contactors	Instructions and Maintenance	GEH-4989
	Renewal Parts	GEF-8017
Load Break Switch (IC1074)	Instructions and Maintenance	GEH-4268



# Medium Voltage Equipment Switchgear — PowerVac Medium Voltage Switchgear

For medium-voltage applications, POWER/VAC<sup>1</sup> metalclad switchgear is available, utilizing POWER/VAC vacuum circuit breakers.

POWER/VAC switchgear is designed to meet a wide variety of protection and switching applications. All functional units such as incoming line, radial feeders, feeder bypass, bus-tie, bus-entrance and auxiliary units are available to give your system-planning staff a wide range of latitude. These basic functions, plus the versatility of one-high or two-high stacking, afford maximum value for your application dollar.

**For pricing and application assistance, contact your local GE sales office.**

For more information on these products, order publications listed in Section 24

[www.geindustrial.com/industrialsystems/wizards/peb\\_oem\\_am/home.htm](http://www.geindustrial.com/industrialsystems/wizards/peb_oem_am/home.htm)



### Instructions/Maintenance

POWER/VAC Vacuum Circuit Breaker with ML-18 Mechanism Type VB1	GEK-86132
POWER/VAC Vacuum Circuit Breaker with ML-17 Mechanism	GEK-39671
POWER/VAC Metalclad Switchgear Types 4.16 and 13.8 for POWER/VAC Circuit Breaker	GEK-39672
Metalclad Switchgear Components (Full Height Frame) for POWER/VAC Circuit Breaker	GEK-90209
Metalclad Switchgear Components Box and "L" frame for POWER/VAC Circuit Breaker	GEK-90215
POWER/VAC Compartment Kits	GEK-103201
Renewal Parts - POWER/VAC Vacuum Circuit Breaker with ML17 Mechanism	GEF-4705
Renewal Parts - POWER/VAC Vacuum Circuit Breaker with ML18 Mechanism	GEK-90218
1500 mVA Bkr	GEK-39671 + DEI-002
27 kV Bkr	DEH-40368

### CSI Specifications

- Medium Voltage
  - Arc Resistant Metal Clad Switchgear
    - 26 13 13.10 Medium Voltage Arc Resistant Metal Clad Switchgear
  - Metal Clad Switchgear
    - 16345 Medium Voltage Switchgear
    - 26 13 13 Medium Voltage Switchgear
    - 26 13 13.10A Medium Voltage Metal Clad Switchgear
  - Metal Enclosed Switchgear
    - 16348 Medium Voltage Metal Clad Switchgear
    - 26 13 13.01 Medium Voltage Metal Clad Switchgear
    - 26 13 13.10A Medium Voltage Metal Clad Switchgear

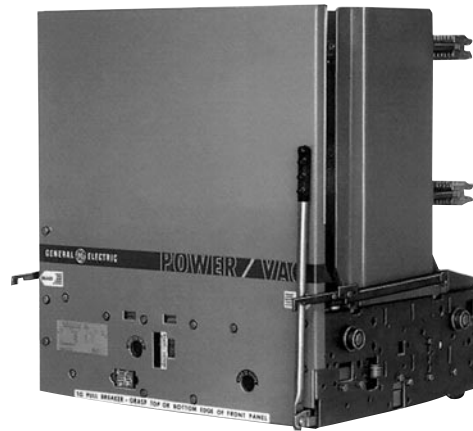

<sup>1</sup>POWER/VAC is manufactured by and is a registered trademark of Powell Industries.





## POWER/VAC Vacuum Metalclad Switchgear, and Breakers

POWER/VAC switchgear is designed, assembled and tested to meet or exceed applicable ANSI, IEEE and NEMA standards. UL Listing is available as option when requested on breakers and cubicles depending on device compliment. POWER/VAC switchgear incorporates the compartment concept with grounded metal barriers that segregate primary functions so no live parts are exposed. Safety interlocks are standard as well as closed door racking and storage, breaker position indicator, and positively-actuated safety shutters. POWER/VAC metalclad switchgear combines the time-honored advantages of GE ANSI designed metalclad switchgear — flexibility, quality and economy, along with the benefits of GE vacuum interruption-improved reliability, longer life, design simplicity, less maintenance, reduced size and weight.

Furthermore, two-high breaker stacking (one breaker above another in a single vertical section) means added application freedom and significant floor space savings. POWER/VAC metalclad switchgear incorporates standardized modular construction to simplify system planning and lower installation cost. These economies are enhanced by the availability of structured protection, instrumentation and control packages.

GE POWER/VAC switchgear is designed to meet a wide variety of protection and switching applications. All functional units such as incoming line, radial feeders, feeder bypass, bus-tie, bus-entrance and auxiliary units are available to give your system planning staff a wide range of latitude. These basic functions, plus the versatility of two-high breaker stacking, afford maximum value for your application dollar.

The modular design of GE metalclad switchgear combines with precision tooled parts, computer-aided design and advanced production techniques to set a new standard of excellence exhibited in the superior reliability figures cited earlier.

### POWER/VAC Equipment

- Ratings—4.76 kV-20KA through 15 kV-63kA
- Two-high breaker stacking can save up to 50% in floor space depending on rating, and results in fewer shipping splits.
- Main bus compartment is completely isolated by metal barriers. All main bus joints have tin plated connections for positive contact and low resistance and are insulated with preformed boots (silver plated optional). Bus bars are provided with high dielectric insulation; they pass through track resistant polyester glass barriers between cubicles. Porcelain insulation to ground is optional.
- Rugged steel frame employs reinforced steel gussets for added strength and dimensional integrity.
- Breakers are directly racked into position on rails which ensure proper alignment of primary and secondary connections.
- Positive stops are provided in TEST/DISCONNECT and CONNECT positions.
- Precision tooling brings uniform quality to breaker and equipment parts and facilitates trouble-free field assembly and operation.
- Auxiliary draw-out trays can be mounted above or below breakers for greater flexibility.

- Arc Resistant designs and Remote Racking/Control options are available for increased safety, and to meet NFPA 70E-2004.
- NEMA 1, NEMA 3R and NEMA 3R Walk-in Construction available
- Ample relay and terminal block space accepts complex configurations. Open doors are securely held with positive stops so breakers can be inserted or withdrawn without damaging control, indication or protective devices.
- Consistent top-quality manufacturing at ISO-9002 listed facility.

### POWER/VAC Breaker

- Vacuum interrupters provide rapid arc interruption and are not affected by the external environment.
- Vacuum interrupter contacts require no maintenance and seldom wear out over the normal duty life-span of a circuit breaker.
- Contact erosion indicator is provided for inspection convenience.
- Primary disconnect fingers are rugged and easy to inspect. Built of silver-plated copper and tested for continuous and momentary currents, these disconnects provide proper contact integrity throughout the life of the gear.
- Breaker ratings: 4.76 kV-20KA through 15 kV-63kA, 1200 Amperes to 4000 Amperes
- Interrupter support of track resistant polyester glass houses vacuum interrupter and primary connection bars. Removed as a unit, it simplifies replacement of vacuum interrupters should they have to be replaced.
- Breaker mechanism is stored energy spring-charged providing fast closing and opening speeds. Parts are high quality precision tooled to close tolerances for operating consistency, reliability, maintenance ease and long life.
- 4000 Amp is fan cooled.

### For more information on these products:

POWER/VAC Descriptive Brochure	DEA-398
POWER/VAC Application Guide	GET-6600
POWER/VAC Vacuum Breaker with ML-18 Mechanism	GEK-86132
POWER/VAC Switchgear Installation Manual	GEK-39672
Medium Voltage Load Interrupter	DEA-052
POWER/VAC Replacement Breakers	DET-095
POWER/VAC Outdoor Distribution Breaker	DET-094

**For pricing and application assistance,  
contact your local GE sales office.**



# Medium Voltage Equipment Switchgear – PowerVac

## Medium-Voltage Switchgear Application Data

POWER/VAC Power Circuit Breaker Characteristics

# Section 15

### Symmetrical Rating Basis ANSI C37.06 (1987)

Identification		Rated Values								Related Required Capabilities				
		Voltage		Insulation Level		Current		Rated Interrupting Time (Cycles) <sup>9</sup>	Rated Permissible Tripping Delay Y, (Seconds)	Rated Maximum rms Voltage Divided by K (kV)	Current Values			
Nominal rms Voltage Class (kV)	Nominal 3-phase Class (MVA) <sup>6</sup>	Rated Maximum rms Voltage (kV) <sup>1</sup>	Rated Voltage Range Factor K <sup>2</sup>	Rated Withstand Test Voltage		Continuous rms Current Rating at 60 Hz (amperes) <sup>7,8</sup>	Short Circuit rms Current Rating (at Rated Max. kV) (kA) <sup>3,4</sup>				3 Sec Short-time Current Carrying Capability	Closing and Latching Capability rms Current (kA)	Close and Latch Peak 2.7K x Short Circuit Current Rating (kA)	Maximum Symmetrical Interrupting Capability <sup>5</sup>
				Low Frequency rms Voltage (kV)	Crest Impulse Voltage (kV)			(kA)	(kA)					
4.16	250	4.76	1.24	19	60	1200-4000	29	5	2	3.85	36	36	58	97
4.16	350	4.76	1.19	19	60	1200-4000	41	5	2	4.0	49	49	78	132
4.16	500 <sup>6</sup>	4.76	1.00	19	60	1200-4000	63	5	2	4.76	63	63	101	170
7.2	500	8.25	1.25	36	95	1200-4000	33	5	2	6.6	41	41	66	111
13.8	500	15	1.30	36	95	1200-4000	18	5	2	11.5	23	23	37	63
13.8	750	15	1.30	36	95	1200-4000	28	5	2	11.5	36	36	58	98
13.8	1000	15	1.30	36	95	1200-4000	37	5	2	11.5	48	48	77	130
13.8	1500 <sup>6</sup>	15	1.00	36	95	1200-4000	63	5	2	15.0	63	63	101	170

<sup>1</sup> Maximum voltage for which the breaker is designed and the upper limit for operation.

<sup>2</sup> K is the ratio of the maximum voltage to the lower limit of the range of operating voltage in which the required symmetrical and asymmetrical interrupting capabilities vary in inverse proportion to the operating voltage.

<sup>3</sup> To obtain the required symmetrical interrupting capability of a circuit breaker at an operating voltage between 1/K times rated maximum voltage and rated maximum voltage, use the following formula:

$$\text{Required Symmetrical Interrupting Capability} = \text{Rated Short-Circuit Current} \times \frac{(\text{Rated Maximum Voltage})}{(\text{Operating Voltage})}$$

For operating voltages below 1/K times rated maximum voltage, the required symmetrical interrupting capability of the circuit breaker shall be equal to K times the rated short-circuit current.

<sup>4</sup> With the limitation stated in 5.10 of ANSI-C37.04-1979, all values apply for polyphase and line-to-line faults. For single phase-to-phase faults, the specific conditions stated in 5.10.2.3 of ANSI-C37.04-1979 apply.

<sup>5</sup> Current values in this column are not to be exceeded even for operating voltages below 1/K times maximum voltage.

<sup>6</sup> MVA Class listed for reference only. Note 4160V-500MVA and 13.8KV-1500MVA are not listed as preferred ratings according to table 2.1 of ANSI-C37.06-1987.

<sup>7</sup> 3500A must be derated for outdoor construction.

<sup>8</sup> 4000A is forced-air cooled, and indoor construction only.

<sup>9</sup> 3 cycle interrupting ratings are available, consult Factory.

### Symmetrical Rating Basis ANSI C37.06 (2000)

Voltage		Rated Values					Rated Interrupting Time (Cycles)	Rated Permissible Tripping Delay, Y (Seconds)	Current	
		Rated Withstand Test Voltage		Continuous rms Current Rating at 60 Hz (amperes) <sup>2</sup>	Short Circuit rms Current Rating (at Rated Max. kV) (kA) <sup>3</sup>	2 Second Short Time Current Carrying Capability (kA)			Close and Latch Peak 2.6K x short circuit rating (kA)	
Rated Maximum rms Voltage (kV) <sup>1</sup>	Rated Voltage Range Factor, K	Low Frequency rms Voltage (kV)	Crest Impulse Voltage (kV)							
4.76	1.0	19	60	1200-4000	31.5	5 or 3	2	31.5	82	
4.76	1.0	19	60	1200-4000	40	5 or 3	2	40	104	
4.76	1.0	19	60	1200-4000	50	5 or 3	2	50	130	
4.76	1.0	19	60	1200-4000	63*	5	2	63	164	
8.25	1.0	36	95	1200-4000	40	5 or 3	2	40	104	
8.25	1.0	36	95	1200-4000	50*	5 or 3	2	50	130	
8.25	1.0	36	95	1200-4000	63*	5	2	63	164	
15	1.0	36	95	1200-4000	20	5 or 3	2	20	52	
15	1.0	36	95	1200-4000	25	5 or 3	2	25	64	
15	1.0	36	95	1200-4000	31.5	5 or 3	2	31.5	82	
15	1.0	36	95	1200-4000	40	5 or 3	2	40	104	
15	1.0	36	95	1200-4000	50	5 or 3	2	50	130	
15	1.0	36	95	1200-4000	63	5	2	63	164	

<sup>1</sup> Maximum voltage for which the breaker is designed and upper limit of operation.

<sup>2</sup> 4000A rating is forced-air cooled, indoor construction only. 3500A must be derated in outdoor construction.

<sup>3</sup> Within the limitations stated in ANSI C37.04-1999, 5.8.

\*Exceeds ANSI C37.06-2000 preferred ratings.



# Medium Voltage Equipment Vacuum Circuit Breakers and Frames

### Type VB POWER/VAC Vacuum Circuit Breakers and Frames

For pricing and application assistance,  
contact your local GE sales office.

#### Features

- VB POWER/VAC skeleton frame is designed for use by OEM switchgear builders.
- Flexibility is offered in various frame configurations allowing breakers to be stacked in a two-tier arrangement.
- Breaker compartment includes racking mechanism, stationary primary disconnects, shutter mechanism and secondary control with ten foot leads for connection to the control circuits.
- Auxiliary compartment includes potential transformer and/or control power transformer roll-out tray. Transformers, fuses and secondary control wiring are supplied by the purchaser.
- Blank compartments are available when required by switchgear line-up arrangement.
- Breaker storage compartment includes breaker storage rails.
- POWER/VAC vacuum breaker elements with all ANSI ratings from 4.16-250mVA through 13.8-1500mVA (ANSI C37.06 1987) and 20kA through 63kA (ANSI C37.06 2000), 1200 amperes through 4000 amperes. 27kV @ 16kA and 25kA available.
- Stored energy, spring-charged operating mechanism for fast closing and tripping.
- Various control voltages for breaker operation are available in ac or dc.
- UL Listing on POWER/VAC Breaker available if specified.
- Skeleton frame UL Recognized component if specified.
- A complete line of accessories is available.
- Additional OEM Components are also available.
  - Box Frames
  - “L” Frames (cradle)
  - Breaker compartment and rollout compartment kits
- Contact your local GE sales office for information.

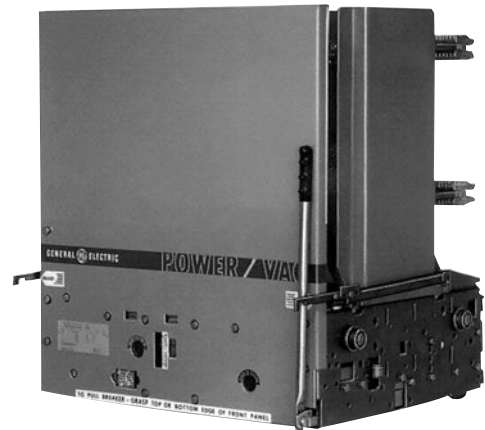

**Type VB1 – 4.16 kV-250 mVA  
1200 ampere breaker element**



**Typical skeleton frame**



PV System 27/38<sup>1</sup> delivers advanced vacuum circuit breaker technology and uncompromising attention to every detail—top to bottom, inside and out. You receive superior performance and functional simplicity.

The metal-clad compartment construction protects via grounded compartments, conductor insulation and live part shielding. When breakers are moved to the test position, grounded aluminum shutters automatically cover both line and load stabs. Each circuit breaker cell features closed-door racking, closed door mechanical trip and lockout features.

The silver-plated tubular copper main bus features fully rated epoxy insulation, and bolted joints use fully qualified vinyl cover boots. Main bus support comes from cycloaliphatic epoxy insulators. Custom designed clamping type stand-off insulators are molded of urethane for tubular bus support. A continuous silver-plated copper ground bus runs the entire length of the assembly. To enhance safety, it can carry the rated short circuit current of the installed circuit breakers for 2 seconds.

The structure allows trouble-free installation and operation. Rear compartment doors simplify installation and inspection. There is ample cable space for either top or bottom entry, and rear terminal areas are customized as needed. Vertical structures can be added later at either end.

PV System 27/38 circuit breakers are powerful, user friendly and reliable. Controls and indicators are clearly identified, and the main springs can be charged from the front as well. True closed-door racking adds a layer of protection.



### Standards

PV System 27 and PV System 38 switchgear is fully tested to all applicable ANSI, IEEE and NEMA standards.

### Product References:

MV Switchgear Selection Guide

DEA-398



**Hipoxy-2000<sup>1</sup> bus insulation delivers high electrical characteristics, and it will not chip, crack or flake.**



**The voltage transformer drawout assembly provides a positive internal ground in the disconnected position. Interlocks and an insulated automatic shutter assembly further enhance safety.**



**A 24-point, front-connected umbilical cord between the breaker and the cubicle forms a secondary control interface that allows both external testing of the control circuitry and positive visual indication of proper connection.**

<sup>1</sup>PV System 27, PV System 38 and Hipoxy-2000 are registered trademarks of Powell Industries.



# Medium Voltage Equipment

## PV System 27 and PV System 38 Switchgear

27-38kV

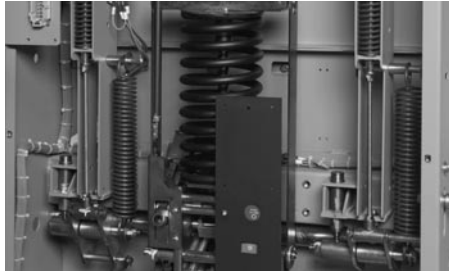

A patented, low-impact mechanism precisely manages the delivery of operating speed and force. Front accessibility simplifies inspections, while fewer moving parts minimize maintenance and maximize reliability.



Generous panel space and auxiliary compartments accommodate protective relays, meters and instruments.



Surrounding the vacuum interrupter on three sides, a housing (which doubles as a phase insulator) makes removal and inspection fast and simple.

### Weights & Dimensions

Voltage (kV)	Continuous Current (A)	Width (in.)	Height (in.)	Depth (in.)	Instrument Door Height (in.)	Weight (lbs.)
27	1200/2000	40	92	116.5	40	3000
38	1200/2000	40	92	116.5	40	3000

### Typical Sections

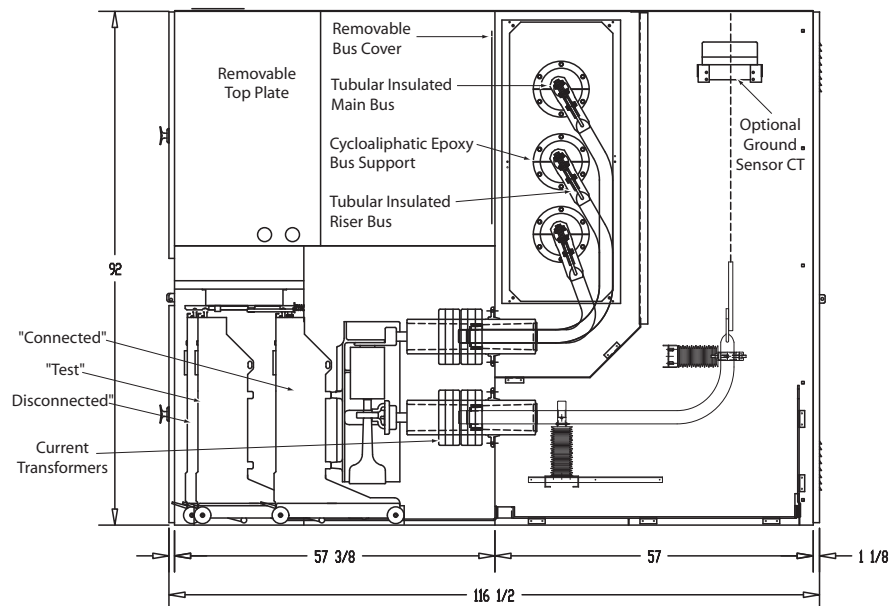

### Circuit Breaker Characteristics

Rated Maximum Voltage (kV rms)	Rated Voltage Range (k Factor)	Insulation Withstand Test Voltages		Rated Continuous Current at 60Hz	Rated Short Circuit at Maximum kV (kA rms)	Rated Interrupting Time (cycles)	Rated Maximum Voltage Divided by K (kV rms)	Maximum Symmetrical Interrupting Capability and Short Time Current (kA rms)	Closing and Latching Capability 2.7K times Rated Short Circuit Current (kA Crest)
		Low Frequency (kV rms)	Full Wave Impulse (kV Crest)						
27	1.0	60	125	1200/2000	25 40	3 3	27.0 27.0	25 40	67 108
38.0	1.0	80	150	1200/2000	40	3 or 5	38.0	40	108

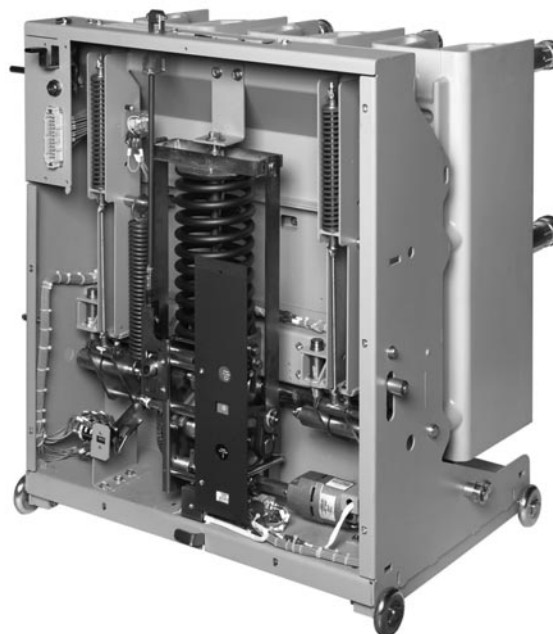

# Medium Voltage Equipment Arc Resistant Switchgear

4.76kV-38kV

## Section 15

Arc resistant switchgear channels the energy released during an internal arc fault in ways that minimize the potential for injury to personnel and damage to surrounding equipment.

Across the line, this switchgear leads the way in arc resistant technology. It's available in ANSI Type 1 or Type 2 construction with no larger footprint than the standard switchgear design.

Circuit breakers are interlocked so they cannot be opened, closed or racked to the connected position with the arc resistant door open. This minimizes the opportunity for operator error.

But arc resistant protection is important at every step, not just when opening and closing the circuit breaker, so our single-latch doors close and engage in a single action, which provides virtually automatic protection for the operator. The pressure release venting panels are maintenance-free.



### Product References:

MV Switchgear Selection Guide

DEA-398



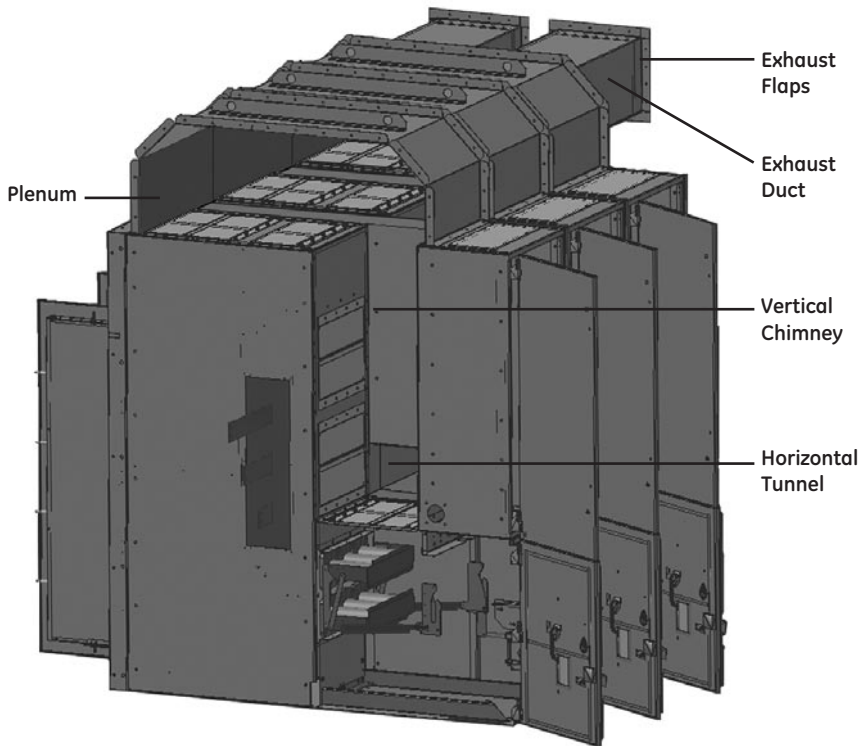

The arc resistant rear access door with secure latch pins.



The arc resistant rear doors and plenum of a two-high design.

This arc resistant design can reduce the NFPA-70E requirement for personal protective equipment (PPE).



The plenum allows for indoor installation of arc resistant switchgear.

**Type 1 & Type 2 Configurations (IEEE C.37.20.7.2001)**

Feature	4.76-15kV		27-38kV	
	Type 1	Type 2	Type 1	Type 2
Front cells and front doors employ unique arc resistant construction	✓	✓	✓	✓
Rear cells and rear doors employ unique arc resistant construction		✓		✓
Pressure relief vents on circuit breaker and auxiliary bus compartments	✓	✓	✓	✓
Pressure relief vents on circuit breaker, main bus and cable connection compartments	✓	✓	✓	✓
Available with one circuit breaker or auxiliary rollout per section	✓	✓	✓	✓
Available with one or two circuit breakers per section (maximum 3000A connected load)	✓	✓		
No external openings on front of the equipment that allow the escape of hot gases or debris	✓	✓	✓	✓
No external openings on any exposed side of the equipment to allow the escape of hot gases or debris		✓		✓
All entrances into the instrument compartments made with a fitting designed to minimize entrance of gas during a fault	✓	✓	✓	✓
Closed door racking of circuit breakers	✓	✓	✓	✓
Closed door racking of all VTs and CPTs	✓	✓		





# Medium Voltage Equipment

## Arc Resistant Switchgear

4.76kV-38kV  
Specifications

# Section 15

### Standards

Arc resistant switchgear is fully tested to all applicable ANSI, IEEE and NEMA standards.

### Ratings & Dimensions

Voltage (kV)	Ratings		Configuration				Dimensions <sup>3</sup> (in.)			
	Continuous Current (Amperes)	Maximum Internal Arcing Short-Circuit Current <sup>1</sup> (kA)	Circuit Breaker Lower	Rollout Lower <sup>4</sup>	Circuit Breaker Upper	Rollout Upper <sup>4</sup>	Width (in.)	Height (in.)	Depth (in.)	Instrument Door Height (in.)
5	1200/2000	50	X				26	95	89	57
5	1200/2000	50		X(2)			26	95	89	19
5	1200	50	X		X		26	95	89	19
5	1200/2000	50	X			X(2)	26	95	89	19
5/15	1200/2000	63	X				36	95/105	95/105	50/60
5/15	1200/2000	63		X			36	95/105	95/105	50/60
5/15	1200/2000	63	X		X		36	95/105	105	9/19
5/15	1200/2000	63	X			X	36	95/105	95/105	25/35
5/15	3000	63	X				36	95/105	95/105	50/60
5/15	3000	63	X			X	36	105	105	60
5/15	4000 <sup>2</sup>	50	X				36	95/105	95/105	50/60
27/38	1200/2000	40	X				40	92	116.5	40

<sup>1</sup> Internal Arcing Short-Circuit Current is based on IEEE C37.20.7 Type 2 with the recommended fault duration of 0.5s.

<sup>2</sup> 4000A designs are forced-cooled. No devices may be placed above the circuit breaker.

<sup>3</sup> Dimensions may be altered based on Internal Arcing Short-Circuit Current and configuration. Height does not include a plenum.

Add 30 inches for standard plenum designs. Overall dimensions for a line-up of switchgear will be based on the largest size requirements for any given section.

<sup>4</sup> In the 26" design it is possible to have two auxiliary rollout devices in the upper or lower positions, indicated by (2). In 36" designs only one auxiliary rollout is possible in a given location.

<sup>5</sup> Approximate useable space on instrument door will be less than shown.

### Typical 27/38kV Sections

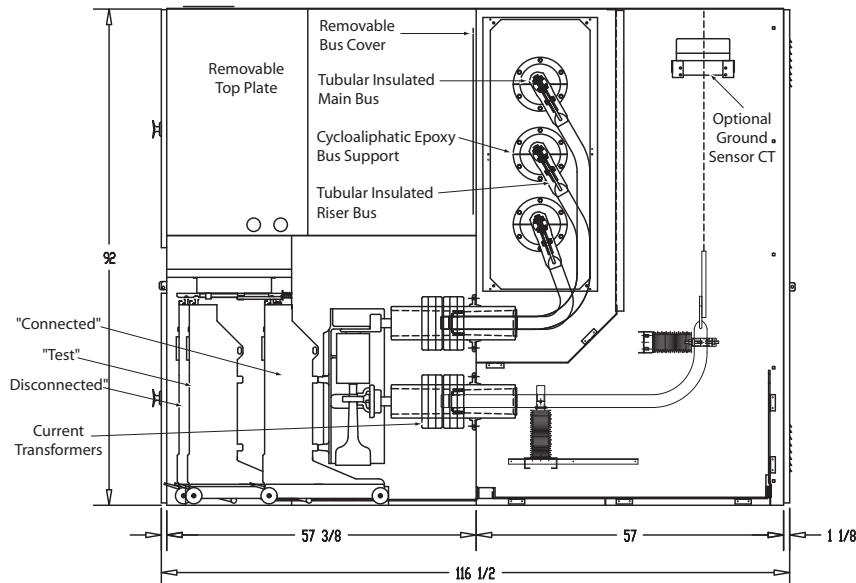

Typical 15kV Sections

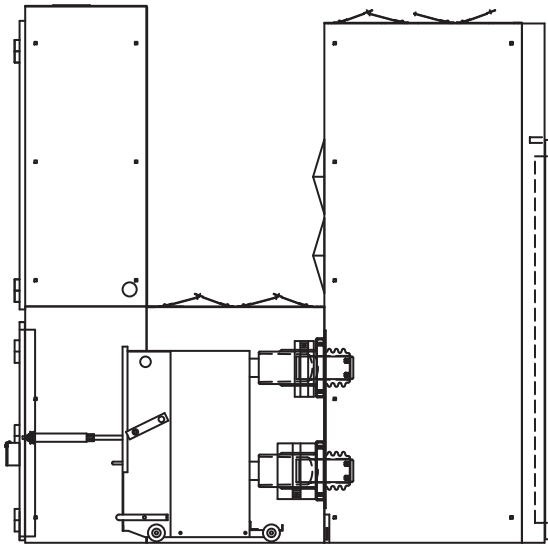

One-high construction with circuit breaker in the lower compartment and venting above  
(95/105" high x 95/105" deep)

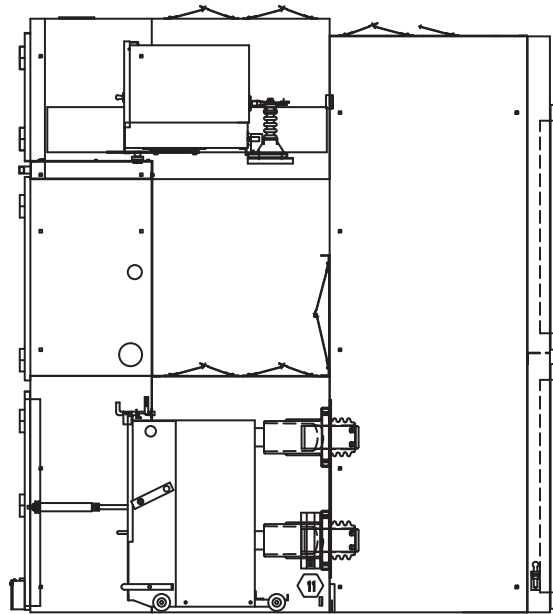

One-high construction with circuit breaker in the lower compartment and a PT/CPT roll-out above  
(95/105" high x 95/105" deep)

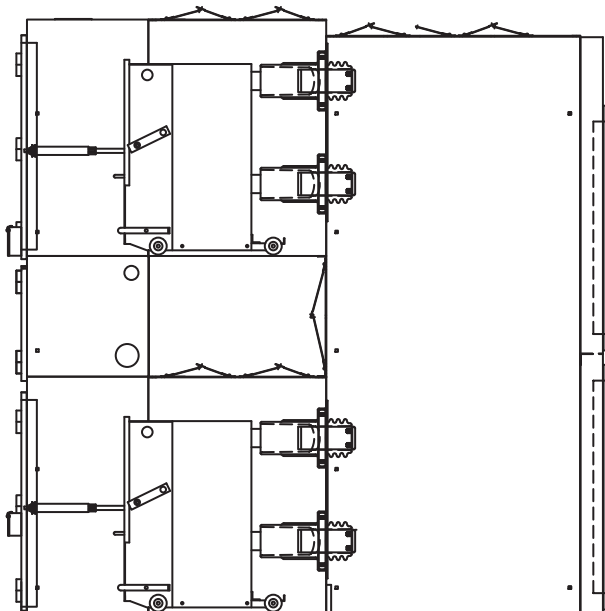

Two-high construction with circuit breaker in the lower and upper compartments  
(95/105" high x 105" deep)



### BreakMaster™ Load Interrupter Switch

**BreakMaster™: rugged, efficient, versatile load switching and protection**

GE's BreakMaster™ load interrupter switches provide dependable, economical load switching and protection for medium voltage circuit applications from 2.4kV through 15kV in 600 or 1200 ampere load interrupting ratings.

The BreakMaster™ switch consists of a 2-position (open, closed), 3-pole, gang-operated, air interrupter switch utilizing a spring charged mechanism for both closing and opening functions. It is operated externally from the front of the cubicle and is equipped with a quick make/quick break mechanism that opens and closes the switch regardless of the speed at which the operating handle is moved.

Used mainly as a primary or secondary disconnect switch for transformers, the variety of configurations in which BreakMaster™ is available also make it useful for specific distribution needs. It can, for example, be inserted as a main or feeder switch in PowerVac switchgear or Limitamp® motor controller lineups. Fault current protection is available using a complete line of current limiting or expulsion fuses.

BreakMaster™ components are manufactured under strict quality guidelines, and they meet or exceed all applicable ANSI, NEMA, and IEEE standards, plus IEC 60265 for limited purpose switches. UL Listed switches are available for most standard configurations and options. When required, BreakMaster™ switches also meet the seismic requirements of the IBC 2003 building codes. All steel surfaces are chemically cleaned prior to painting with an ANSI 61 finish that is rated for 1000-hour salt spray. Refer to the factory for additional color options.



#### References:

Operating and Installation Manual	DEH-40291
BreakMaster™ Brochure	DEA-052
Current-Limiting Power Fuses	GEA-7137
How to Select and Apply Type EJO-1, 9F62	GET-6779
GE Power Fuses Product Catalog	GEP-9013



# Medium Voltage Equipment

## Metal Enclosed Load Interrupter Switches – BreakMaster™

### Typical User Configurations

The complete line of BreakMaster™ load interrupter switches can fill most distribution system requirements. They are available in a variety of configurations to meet specific distribution needs, including: single switches, two-position no-load break selector switches, duplex switches, and line-ups. Motor operators, customer metering and outdoor construction are also available.

Standard Configuration Features	Single	Duplex	Selector	Line-up	ATS
35" width	•		•		
70" width		•			
115" width					•
90" indoor height, 99" outdoor height	•	•	•	•	•
50" depth standard (includes arrester if required), 60" depth available	•	•		•	
90" depth (requires rear access to equipment)			•		
Available section widths: 55" mains/tie; 35" branches; 20" / 35" incoming terminal compartments; 20" / 35" / 40" auxiliary sections				•	
Extension required for oil-filled transformers only (18" wide)	•	•	•	•	•
60" depth					•
Dry type and cast coil transformers require 3" in throat for outdoor enclosure	•	•	•	•	•
Key interlocking standard between switches and fuse compartment		•	•		•

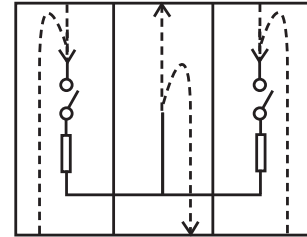

Automatic Transfer

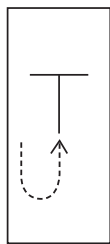

Incoming

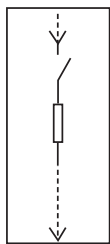

Single

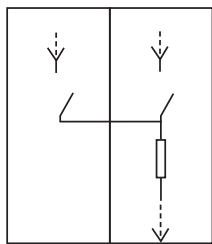

Duplex

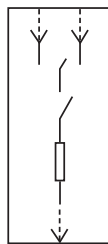

Selector

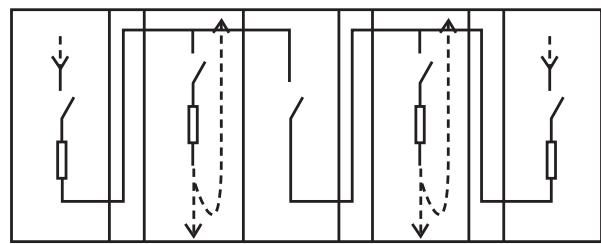

Line-up (main-tie-main)

### Switch Ratings

(In accordance with standards in table at bottom right)

Max kV	Impulse Withstand kV (BIL)	Amperes Continuous and Interrupting	Momentary Switch Closed Asym	Fault Close Asym
5.0	60	600	40,000	40,000
		600	61,000	61,000
		1,200	40,000	40,000
	95	1,200	61,000	61,000
		600	40,000	40,000
		600	61,000	61,000
15.0	95	1,200	40,000	40,000
		1,200	61,000	61,000
		1,200	40,000	40,000
	95	600	40,000	40,000
		600	61,000	61,000
		1,200	40,000	40,000
		1,200	61,000	61,000

### Fuse Ratings

Fuse	Fuse Type	Voltage Class	Ampere Range
Current Limiting Fuses	EJ0-1	5 kV	25A - 900A
	EJ0-1	15 kV	20A - 300A
Expulsion Fuses	SM-4	5 kV	3A - 200A
	SM-4	15 kV	3A - 200A
	SM-5	5 kV	3A - 400A
	SM-5	15 kV	3A - 400A
	RBA200	5 kV - 15 kV	40A - 200A
	RBA400	5 kV - 15 kV	20A - 300A
	RBA800	5 kV - 15 kV	450A - 720A

For a complete list of available fuses, contact factory.

### Typical Weights

Configuration	Weight (lbs.)	
	NEMA 1	NEMA 3R
Single	1200	1550
Selector	2500	3200
Duplex	2500	3200
Mains/Ties	1800	2400
Branch	1200	1550
20" wide incoming cable	600	850
35" wide incoming cable	1050	1400
ATS	3500	4200

### Standards

ANSI/IEEE	C37.20.3
	C37.20.4
	C37.22
NEMA	SG-6
IEC	60265 <sup>1</sup>
UL	See ANSI standards
CSA/cUL	C22.2, No. 31
	C22.2, No. 193

<sup>1</sup>Limited purpose switches only.



# Medium Voltage Equipment

## Metal Enclosed Load Interrupter Switches – BreakMaster™

### Typical Dimensions

#### Typical BreakMaster™ Dimensions

		W	H	D
Single	Indoor	35 <sup>1</sup>	90"	50" or 60"
	Outdoor	35 <sup>1</sup>	99"	60" or 70"
Duplex	Indoor	70 <sup>2</sup>	90"	50" or 60"
	Outdoor	70 <sup>2</sup>	99"	60" or 70"
Selector	Indoor	35 <sup>2</sup>	90"	90 <sup>3</sup>
	Outdoor	35 <sup>2</sup>	99"	100 <sup>3</sup>
Incoming	Indoor	20" or 35"	90"	50" or 60"
	Outdoor	20" or 35"	99"	60" or 70"

<sup>1</sup>Motor operated switch is 40" wide.

<sup>2</sup>Not available with motor operator.

<sup>3</sup>Requires rear access.

#### Automatic Transfer Dimensions

	W	H	D
Indoor	115"	90"	60"
Outdoor	115"	99"	60"

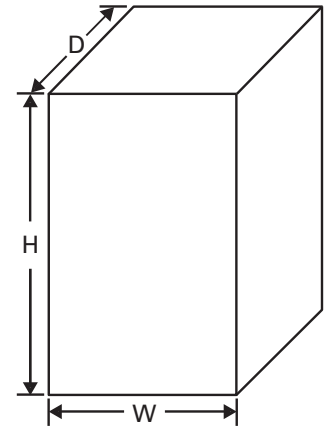



An array of optional multi-function meters measure volts, amps, frequency, power factor, watts and VARs, and can communicate via RS-232, RS-485, Commnet and Modbus. For safety, an enclosed, low voltage panel completely isolates metering components.



While accessing fuses, split doors prevent access to the live side of the switch when the lower door is open. Oversized viewing window and switch position markers allow visual verification of switch position.



Full height interphase barriers are standard on all switches. Both current limiting and expulsion fuses are available.



Standard 50" section depth provides substantial space for incoming or outgoing cables. 60" depth is also available when customer preference and/or specific options require additional space.



Horizontal barriers between the switch mechanism and fuse compartment are a standard safety feature.



Convenient split rear covers provide easy access to cable terminations or devices located in the rear of the section.

### Standard Features

- Copper silver-plated bus
- Full length ground bus
- Polyester coat paint
- ANSI 61 paint color (gray)
- Oversized viewing window
- Full height interphase barriers
- 11 gauge doors, barriers and covers
- Generous cable termination area
- Permanent non-corrosive nameplate
- Individual doors over switch and fuses
- Concealed door hinges
- Switch padlock provisions
- Key interlock provisions
- Split rear and side covers
- Tungsten-tipped arc interrupting blades
- Mechanical switch and door interlocking
- Louvered ventilation at top and bottom
- Safety horizontal barrier

### Standard Outdoor Features

- Removable filters for louvers
- Long life space heaters
- 4" channel base
- Sloped roof
- Bottom closure plates
- Rodent barriers

### Optional Accessories and Features

- UL /cUL listing
- Copper tin-plated bus
- Insulated bus and bus boots over joints
- 80kA momentary bus rating
- Dust resistant enclosure
- Rear doors (full height or double)
- Vertical barriers
- Bottom closure plates
- Seismic Zone 4 bracing
- Tamper resistant hardware
- Auxiliary switches (2NO-2NC)
- Thermostat
- Space heater (standard on outdoor, optional on indoor)
- Porcelain insulators
- Customer metering
- Drawout CPT
- Automatic transfer (pending)
- Surge arresters
- Mimic bus
- Space heater on/off switch
- Ground studs
- Convenience light
- Duplex receptacle
- Top hat
- Run back bus
- Draw out PTs and CTs
- Metal screen barrier
- Live line indicators
- Utility Metering Compartments
- Ground switch
- Special color paint
- Blown fuse indication
- Blown fuse operation
- Direct coupled operator



All Current-Limiting Power Fuses, Fuse Supports,  
Fuse Disconnect Switches and Spare Parts are  
now available from  
**Ferraz Shawmut: [us.ferrazshawmut.com](http://us.ferrazshawmut.com)**

### USA

374 Merrimac Street  
Newburyport, MA 01950  
T: 978-462-6662  
F: 978-462-0181

### Canada

88 Horner Avenue  
Toronto, Ontario, M8Z 5Y3  
T: 416-252-9371  
F: 416-252-6572

### France

1, Rue Jean Novel  
69100 Villeurbanne  
T: 04-72-22-66-11  
F: 04-72-22-67-13



